

Work Order No.: LEC-1119	Date: 26/11/2020	Site Condition : Constructed
Enquiry No.: E-10149	Date: 25/11/2020	User : Anubhav
Dispatch No.:	Disp Date :	Meeting Done : No
Through (Transport & GR No):		Enquiry Source : Existing Client
Target Date:		Remark : Poultry
Customer: M/s Alpine Poultrys, Patiala, Punjab		

INDIVIDUAL MACHINE

**Note: 1. Conveyor is without foundation attachment, v-belt & motor.
2. One plate without welding & attachment lock pin will add with it.(Discuss with Jasbir Ji)**

1) <u>Screw Conveyor (SC-1010)</u>	(For Grinder)
Job No.:	
With	
1. Motor Pulley (4" 2B) and Auger Pulley (12" 2B)	
2. Control Gate (Lever Type)	
3. Inlet Grill	
4. Outlet	

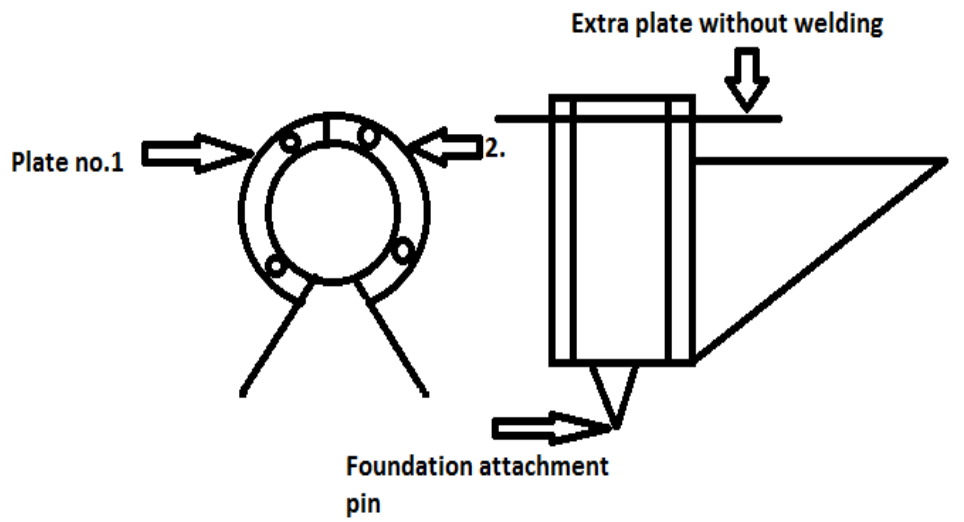

PREPARED BY	CHECKED BY	CHECKED BY	APPROVED BY