

ALL THE DIMENSIONS ARE IN MM OTHERWISE MENTIONED.
ALL THE SHARP EDGES MUST BE REMOVED.
PLEASE DESTROY THE OLD REVISION OF THIS DRAWING

THIS DRG. IS SOLE PROPERTY OF LARK ENGG. CO. (INDIA) PVT. LTD.
UNAUTHORISED USE OF THIS DRG. OR MAKING PRODUCT
DRG. WITHOUT OUR PERMISSION OR ANY OTHER MISUSE IS NOT PERMITTED.

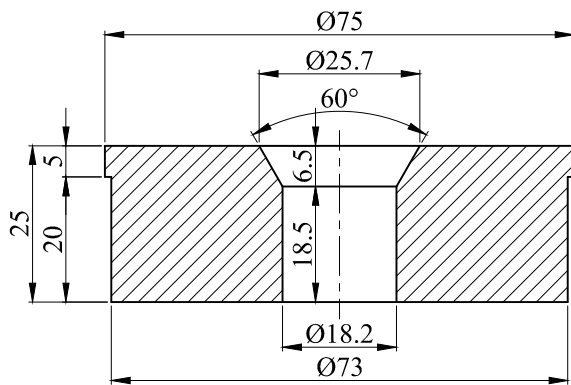

Sec View 'AA'

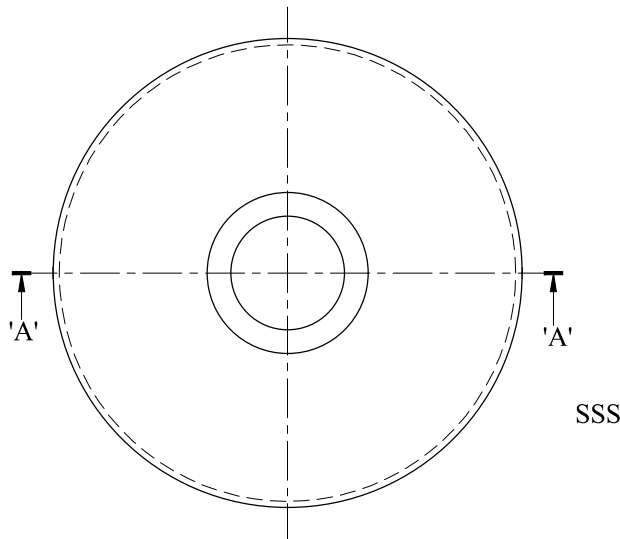
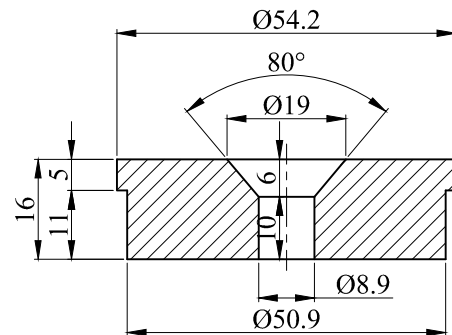
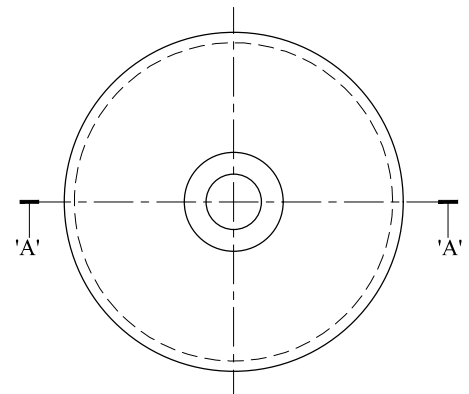
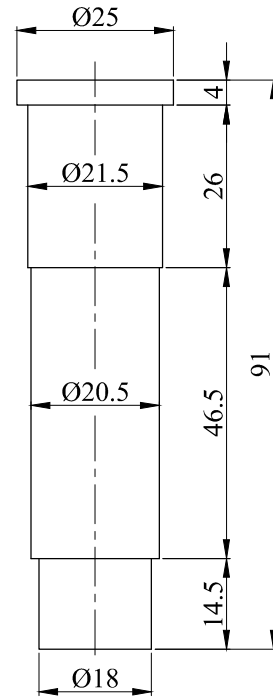

Sec View 'AA'

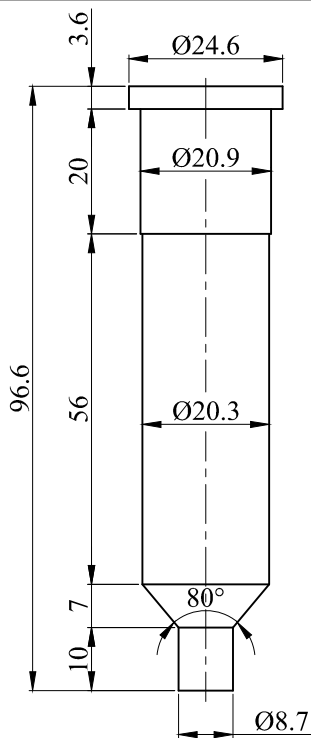

UNSPECIFIED TOLERANCES in MM (ISO 2768-1)

0 TO 06	±0.05	120 TO 400	±0.2
06 TO 30	±0.1	400 TO 1000	±0.3
30 TO 120	+0.15	1000 TO 2000	+0.5

SURFACE FINISH										
IS: 3073-1967 Ra VALUE -um	0.025 ✓	0.1 ✓	0.2 ✓	0.8 ✓	1.6 ✓	6.3 ✓	12.5 ✓	25 ✓	50 ✓	100 ✓



LARK

LARK ENGG. CO. (INDIA) PVT. LTD.

I.T.I., SASOULI ROAD, YAMUNA NAGAR. PH.: 91-01732-254685, 259685
Find us at : www.larkenggco.com , e-mail : info@larkenggco.com

TITLE : Punching Press

ITEM: Detail Drg. of Hammer Punched Tool

REFERENCE DRG NO. :

LID -

DRG. NO.

LID - 118

DRN. BY Arvind

CKD. BY

APPD. BY

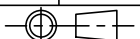

DATE 01-11-18

REV. NO SHT.

00 A4