

## 2. Bearing Selection

Rolling element bearings are available in a variety of types, configurations, and sizes. When selecting the correct bearing for your application, it is important to consider several factors, and analyse in various means.

A comparison of the performance characteristics for each bearing type is shown in **Table 2.1**. As a general guideline, the basic procedure for selecting the most appropriate bearing is shown in the following flow chart.

### 2.1 Bearing selection flow chart

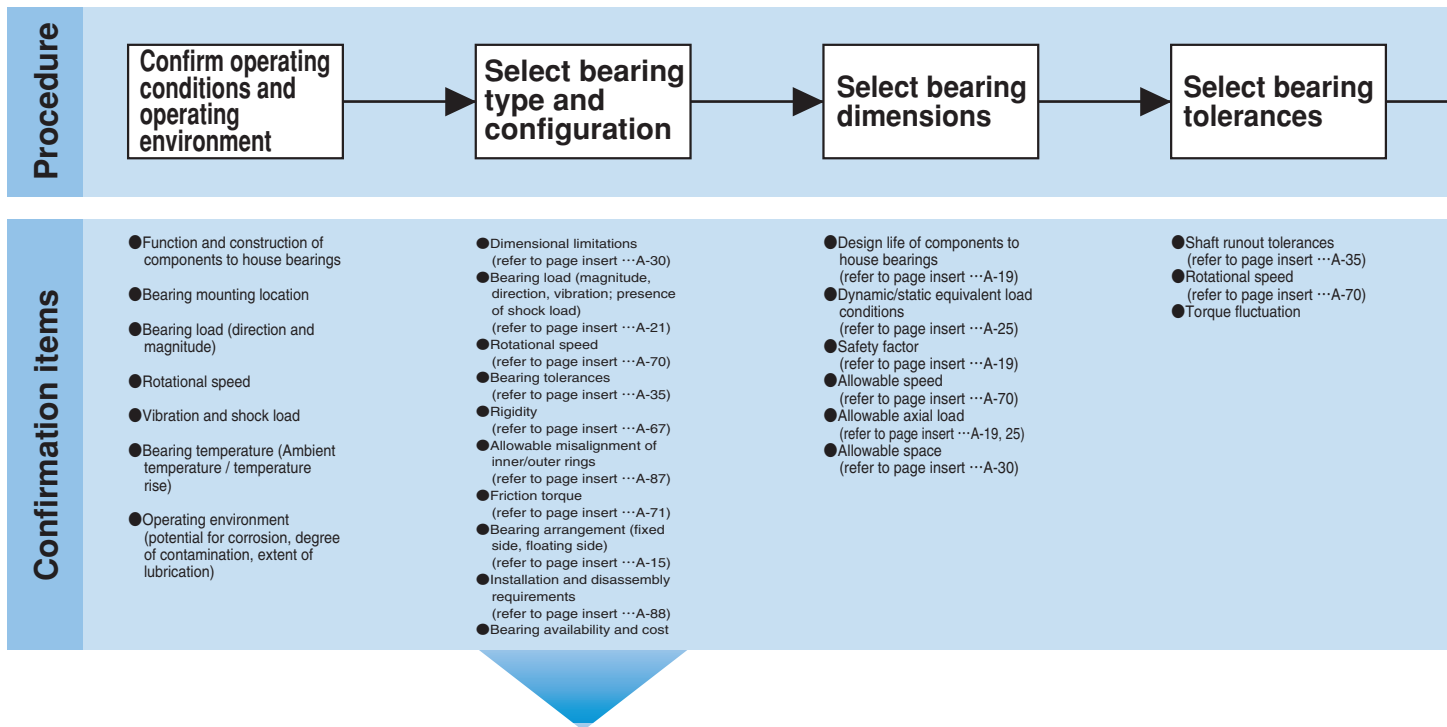

Selection of bearing type and configuration

**(1) Dimensional limitations**  
The allowable space for bearings is generally limited. In most cases, shaft diameter (or the bearing bore diameter) has been determined according to the machine's other design specifications. Therefore, bearing's type and dimensions are determined according to bearing bore diameters. For this reason all dimension tables are organized according to standard bore diameters. There is a wide range of standardized bearing types and dimensions: the right one for a particular application can usually be found in these tables.

**(2) Bearing load**  
The characteristics, magnitude, and direction of loads acting upon a bearing are extremely variable. In general, the basic load ratings shown in bearing dimension tables indicate their load capacity. However, in determining the appropriate bearing type, consideration must also be given to whether the acting load is a radial load only or combined radial and axial load, etc. When ball and roller bearings within the same dimension series are considered, the roller bearings have a larger load capacity and are also capable of withstanding greater vibration and shock loads.

**(3) Rotational speed**  
The allowable speed of a bearing will differ depending upon bearing type, size, tolerances, cage type, load, lubricating conditions, and cooling conditions.  
The allowable speeds listed in the bearing tables for grease and oil lubrication are for normal tolerance NTN bearings. In general, deep groove ball bearings, angular contact ball bearings, and cylindrical roller bearings are most suitable for high speed applications.

**(4) Bearing tolerances**  
The dimensional accuracy and operating tolerances of bearings are regulated by ISO and JIS standards. For equipment requiring high tolerance shaft runout or high speed operation, bearings with Class 5 tolerance or higher are recommended. Deep groove ball bearings, angular contact ball bearings, and cylindrical roller bearings are recommended for high rotational tolerances.

**(5) Rigidity**  
Elastic deformation occurs along the contact surfaces of a bearing's rolling elements and raceway surfaces under loading. With certain types of equipment it is necessary to reduce this deformation as much as

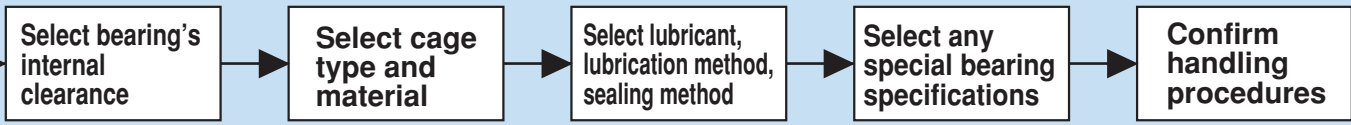

- Material and shape of shaft and housing (refer to page insert ...A-85)
- Fit (refer to page insert ...A-49)
- Temperature differential between inner/outer rings (refer to page insert ...A-59)
- Allowable misalignment of inner/outer rings (refer to page insert ...A-87)
- Load (magnitude, nature) (refer to page insert ...A-21)
- Amount of preload (refer to page insert ...A-66)
- Rotational speed (refer to page insert ...A-70)

- Rotational speed (refer to page insert ...A-70)
- Noise level
- Vibration and shock load
- Momentary load
- Lubrication type and method (refer to page insert ...A-72)

- Operating temperature (refer to page insert ...A-72)
- Rotational speed (refer to page insert ...A-70)
- Lubrication type and method (refer to page insert ...A-72)
- Sealing method (refer to page insert ...A-80)
- Maintenance and inspection (refer to page insert ...A-94)

- Operating environment (high/low temperature, vacuum, pharmaceutical, etc.)
- Requirement for high reliability

- Installation-related dimensions (refer to page insert ...A-86)
- Installation and disassembly procedures (refer to page insert ...A-88)

possible. Roller bearings exhibit less elastic deformation than ball bearings. Furthermore, in some cases, bearings are given a load in advance (preloaded) to increase their rigidity. This procedure is commonly applied to deep groove ball bearings, angular contact ball bearings, and tapered roller bearings.

### (6) Misalignment of inner and outer rings

Shaft flexure, variations in shaft or housing accuracy, and fitting errors, result in a certain degree of misalignment between the bearing's inner and outer rings. In cases where the degree of misalignment is relatively large, self-aligning ball bearings, spherical roller bearings, or bearing units with self-aligning properties are the most appropriate choices. (Refer to **Fig. 2.1**)

### (7) Noise and torque levels

Rolling bearings are manufactured and processed according to high precision standards, and therefore generally produce only slight amounts of noise and torque. For applications requiring particularly low-noise or low-torque operation, deep groove ball bearings and cylindrical roller bearings are most appropriate.

### (8) Installation and disassembly

Some applications require frequent disassembly and reassembly to enable periodic inspections and repairs. For such applications, bearings with separable inner/outer rings, such as cylindrical roller bearings, needle roller bearings, and tapered roller bearings are most appropriate. Incorporation of adapter sleeves simplifies the installation and disassembly of self-aligning ball bearings and spherical roller bearings with tapered bores.

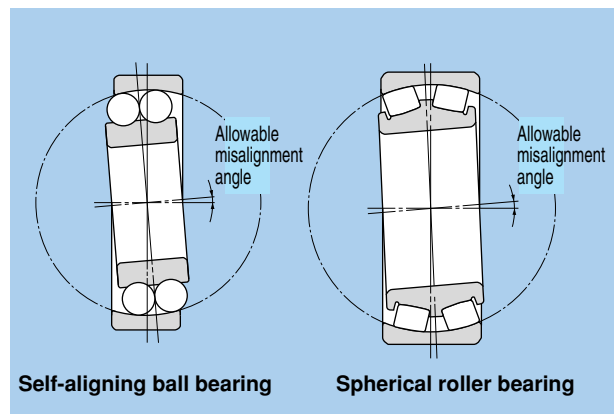

Fig. 2.1

## 2.2 Type and characteristics

Table 2.1 shows types and characteristics of rolling bearings.

Table 2.1 Type of rolling bearings and performance comparison

Bearing types	Deep groove ball bearings	Angular contact ball bearings	Double row angular contact ball bearings	Duplex angular contact ball bearings	Self-aligning ball bearings	Cylindrical roller bearings	Single-flange cylindrical roller bearings	Double-flange cylindrical roller bearings	Double row cylindrical roller bearings	Needle roller bearings
Characteristics										
Load Carrying Capacity										
Axial load										
High speed <sup>①</sup>	☆☆☆☆	☆☆☆☆	☆☆	☆☆☆	☆☆	☆☆☆☆	☆☆☆☆	☆☆☆☆	☆☆☆☆	☆☆☆☆
Accuracy under high speed <sup>①</sup>	☆☆☆	☆☆☆	☆☆	☆☆☆		☆☆☆	☆☆	☆	☆☆☆	
Low noise/vibration <sup>①</sup>	☆☆☆☆	☆☆☆		☆		☆	☆	☆	☆	☆
Low friction torque <sup>①</sup>	☆☆☆☆	☆☆☆		☆☆	☆	☆				
High rigidity <sup>①</sup>			☆☆	☆☆		☆☆	☆☆	☆☆	☆☆☆	☆☆
Vibration/shock resistance <sup>①</sup>			☆		★	☆☆	☆☆	☆☆	☆☆	☆☆
Allowable misalignment for inner/outer rings <sup>①</sup>	☆				☆☆☆	☆				
Stationary in axial direction <sup>②</sup>	⊙	○	⊙	⊙ For DB and DF arrangement	⊙		○	⊙		
Moveable in axial direction <sup>③</sup>	○		○	○ For DB arrangement	○	⊙			⊙	⊙
Separable of inner and outer rings <sup>④</sup>						○	○	○	○	○
Tapered bore inner ring <sup>⑤</sup>					○	○			○	
Remarks		Duplex arrangement required				NU, N type	NJ, NF type	NUP, NP, NH type	NNU, NN type	NA type
Reference page	B-5	B-43	B-60	B-43	B-65	B-77	B-77	B-77	B-102	—

Tapered roller bearings	Double-row, 4-row tapered roller bearings	Spherical roller bearings	Thrust ball bearings	Thrust cylindrical roller bearings	Thrust spherical roller bearings	Reference page	Bearing types
							Characteristics
							Load Carrying Capacity
							Radial load
							Axial load
☆☆☆	☆☆	☆☆	☆	☆	☆	A-70	High speed <sup>①</sup>
☆☆☆	☆		☆			A-35	Accuracy under high speed <sup>①</sup>
			☆			—	Low noise/vibration <sup>①</sup>
						A-71	Low friction torque <sup>①</sup>
☆☆	☆☆☆☆	☆☆☆☆		☆☆☆	☆☆☆	A-58	High rigidity <sup>①</sup>
☆☆	☆☆☆	☆☆☆☆		☆☆☆	☆☆☆	A-21	Vibration/shock resistance <sup>①</sup>
☆		☆☆☆		★	☆☆☆	A-85	Allowable misalignment for inner/outer rings <sup>①</sup>
○	⊙	⊙	○	○	○	A-15	Stationary in axial direction <sup>②</sup>
	○	○	○			A-15	Moveable in axial direction <sup>③</sup>
○	○		○	○	○	—	Separable of inner and outer rings <sup>④</sup>
		○				A-85	Tapered bore inner ring <sup>⑤</sup>
Duplex arrangement required				Including thrust needle roller bearing		—	Remarks
B-119	B-119	B-219	B-257	—	B-257		Reference page

- ① ☆ The number of stars indicates the degree to which that bearing type displays that particular characteristic. ★ Not applicable to that bearing type.
- ② ⊙ Indicates dual direction. ○ Indicates single direction axial movement only.
- ③ ⊙ indicates movement in the axial direction is possible for the raceway surface; ○ indicates movement in the axial direction is possible for the fitting surface of the outer ring or inner ring.
- ④ ○ Indicates both inner ring and outer ring are separable.
- ⑤ ○ Indicates inner ring with tapered bore is possible.

## 2.3 Selection of bearing arrangement

Shafts or axles are generally supported by a pair of bearings in the axial and radial directions. The bearing which prevents axial movement of the shaft relative to the housing is called the **"fixed side bearing"** and the bearing which allows axial movement relatively is called the **"floating-side bearing"**. This allows for expansion and contraction of the shaft due to temperature variation and enables error in bearing mounting clearance to be absorbed.

The **fixed side bearing** is able to support radial and axial loads. A bearing which can fix axial movement in both directions should therefore be selected. A **floating-side bearing** that allows movement in the axial direction while supporting a radial load is desirable. Movement in the axial direction occurs on the raceway surface for bearings with separable inner and outer rings such as

cylindrical roller bearings, and occurs on the fitting surface for those which are not separable, such as deep groove ball bearings.

In applications with short distances between bearings, shaft expansion and contraction due to temperature fluctuations is slight, therefore the same type of bearing may be used for both the fixed-side and floating-side bearing. In such cases it is common to use a set of matching bearings, such as angular contact ball bearings, to guide and support the shaft in one axial direction only.

**Table 2.2 (1)** shows typical bearing arrangements where the bearing type differs on the fixed side and floating side. **Table 2.2 (2)** shows some common bearing arrangements where no distinction is made between the fixed side and floating side. Vertical shaft bearing arrangements are shown in **Table 2.2 (3)**.

**Table 2.2 (1) Bearing arrangement (distinction between fixed and floating-side)**

Arrangement		Comment	Application (Reference)
Fixed	Floating		
		<ol style="list-style-type: none"> <li>1. General arrangement for small machinery.</li> <li>2. For radial loads, but will also accept axial loads.</li> </ol>	Small pumps, auto-mobile transmissions, etc.
		<ol style="list-style-type: none"> <li>1. Suitable when mounting error and shaft deflection are minimal or used for high rotational speed application.</li> <li>2. Even with expansion and contraction of shaft, floating side moves smoothly.</li> </ol>	Medium-sized electric motors, ventilators, etc.
		<ol style="list-style-type: none"> <li>1. Radial loading and dual direction of axial loading possible.</li> <li>2. In place of duplex angular contact ball bearings, double-row angular contact ball bearings are also used.</li> </ol>	Worm reduction gear
		<ol style="list-style-type: none"> <li>1. Heavy loading capable.</li> <li>2. Shafting rigidity increased by preloading the two back-to-back fixed bearings.</li> <li>3. Requires high precision shafts and housings, and minimal fitting errors.</li> </ol>	Reduction gears for general industrial machinery
		<ol style="list-style-type: none"> <li>1. Allows for shaft deflection and fitting errors.</li> <li>2. By using an adaptor on long shafts without screws or shoulders, bearing mounting and dismounting can be facilitated.</li> <li>3. Self-aligning ball bearings are used for positioning in the axial direction, and not suitable for applications requiring support of axial load.</li> </ol>	General industrial machinery
		<ol style="list-style-type: none"> <li>1. Widely used in general industrial machinery with heavy and shock load demands.</li> <li>2. Allows for shaft deflection and fitting errors.</li> <li>3. Accepts radial loads as well as dual direction of axial loads.</li> </ol>	Reduction gears for general industrial machinery
		<ol style="list-style-type: none"> <li>1. Accepts radial loads as well as dual direction axial loads.</li> <li>2. Suitable when both inner and outer ring require tight fit.</li> </ol>	Reduction gears for general industrial machinery
		<ol style="list-style-type: none"> <li>1. Capable of handling large radial and axial loads at high rotational speeds.</li> <li>2. Maintains clearance between the bearing's outer diameter and housing inner diameter to prevent deep groove ball bearings from receiving radial loads.</li> </ol>	Transmissions for diesel locomotives

Table 2.2 (2) Bearing arrangement (no distinction between fixed and floating-side)

Arrangement	Comment	Application (Reference)
	<ol style="list-style-type: none"> <li>1. General arrangement for use in small machines.</li> <li>2. Preload is sometimes applied by placing a spring on the outer ring side surface or inserting a shim. (can be floating-side bearings.)</li> </ol>	Small electric motors, small reduction gears, etc.
	<ol style="list-style-type: none"> <li>1. Back to back arrangement is preferable to face to face arrangement when moment load applied.</li> <li>2. Able to support axial and radial loads; suitable for high-speed rotation.</li> <li>3. Rigidity of shaft can be enhanced by providing preload.</li> </ol>	Machine tool spindles, etc.
	<ol style="list-style-type: none"> <li>1. Capable of supporting extra heavy loads and impact loads.</li> <li>2. Suitable if inner and outer ring tight fit is required.</li> <li>3. Care must be taken that axial clearance does not become too small during operation.</li> </ol>	Construction equipment, mining equipment sheaves, agitators, etc.
<p>Back to back</p> <p>Face to face</p>	<ol style="list-style-type: none"> <li>1. Withstands heavy and shock loads. Wide range application.</li> <li>2. Shaft rigidity can be enhanced by providing preload, but make sure preload is not excessive.</li> <li>3. Back-to-back arrangement for moment loads, and face-to-face arrangement to alleviate fitting errors.</li> <li>4. With face-to-face arrangement, inner ring tight fit is facilitated.</li> </ol>	Reduction gears, front and rear axle of automobiles, etc.

Table 2.2 (3) Bearing arrangement (Vertical shaft)

Arrangement	Comment	Application (Reference)
	<ol style="list-style-type: none"> <li>1. When fixing bearing is a duplex angular contact ball bearing, floating bearing should be a cylindrical roller bearing.</li> </ol>	Vertically mounted electric motors, etc.
	<ol style="list-style-type: none"> <li>1. Most suitable arrangement for very heavy axial loads.</li> <li>2. Shaft deflection and mounting error can be absorbed by matching the center of the spherical surface with the center of spherical roller thrust bearings.</li> </ol>	Crane center shafts, etc.